

INSTALLATION GUIDE

**& DETAILS FOR POPA PAVERS
02 HB**

INDEX

06 WHAT IS PORCELAIN STONEWARE?

08 WHAT ARE PORCELAIN OUTDOOR PAVERS?12

WHY PORCELAIN PAVERS ARE THE BEST CHOICE?14

OUTDOOR 2CM - 3/4" RANGE

16 TOOLS & HANDLING

18 **INSTALLATION OPTIONS: GENERAL INFORMATION**

20 **A- LAYING DIRECTLY WITHOUT ADHESIVE – PEDESTRIAN USE**

23 A1 - DRY LAYING ON SAND, ON A COMPACTED GRAVEL SUBSTRATE (ROAD BASE)

24 A2 - DRY LAYING ON A DRAINING SUBSTRATE

30 A3 - DRY LAYING ON A CONCRETE PLATFORM

31 A4 - LAYING "ORIENTAL GARDEN" STYLE

32 A5 - LAYING WITH FIXED PEDESTALS ON A CONCRETE PLATFORM

34 **B - LAYING WITH ADHESIVE – FOR LIGHT-WEIGHT VEHICLES**

36 B1 - LAYING WITH ADHESIVE ON A CONCRETE SCREED

37 B2 - LAYING WITH ADHESIVE ON A FULL MORTAR BED



important what this INSTALLATION GUIDE is for

GENERAL INFORMATION, TO BE CHECKED IN RELATION TO EACH SPECIFIC CASE

This installation guide contains indications and suggestions based on real work-site experiences and on continuous exchanges of information with “on the field” experts. The information herein contained, is in any case to be considered **a generic and indicative guideline.**

In practical applications, the solutions and procedures to be adopted, in order to obtain proper workmanship of the laying procedure and in absolute safety for the best end result, **will always have to be determined by a qualified professional expert** and after evaluating the context in which the laying will take place, all the features of the site and the regulations in force in the specific area where the laying job will take place.

We cannot be held neither liable nor responsible for improper use of these indications.

FOR QUALIFIED INSTALLERS ONLY

The information in this installation guide **refers solely to laying procedure and performance, entrusted to qualified professionals**, experienced in laying outdoor paving, who have the necessary equipment to perform such job and are aware of the safety rules and of **all the construction techniques needed to ensure a result in line with the best quality standards.**

We cannot accept any liability for “do-it –yourself” work or work carried out by unqualified and unprofessional personnel.

I. What is PORCELAIN STONEWARE?

Porcelain stoneware is a ceramic material, manufactured by:

- atomized high quality clays, quartz, feldspars and metal oxides;
- pressed the obtained mixture at 400 kg/cm^2 pressure (2200 lbs/square inch);
- fired in industrial kilns at 1200° C to 1400° C (2192° F – 2552° F) to obtain a complete sinterization of the mixture;
- squaring the edges by use of abrasive grinders.

Basically, this process industrially creates pieces of man-made stone. This material is dense, waterproof and durable; the product is exceptionally strong, and hard and is highly resistant to staining.

Water absorption is less than 0.05% (required value: 0.5%).

The density of porcelain stoneware is 2300 kg/m^3 (137.3 lbs/cu. ft):

- concrete has a density of about 1600 kg/m^3 (50 to 56.2 lbs/cu. ft)
- marble granite has a density of 2100 kg/m^3 ($68,7 \text{ lbs/cu. ft}$).
- weight / sqft 9 lb

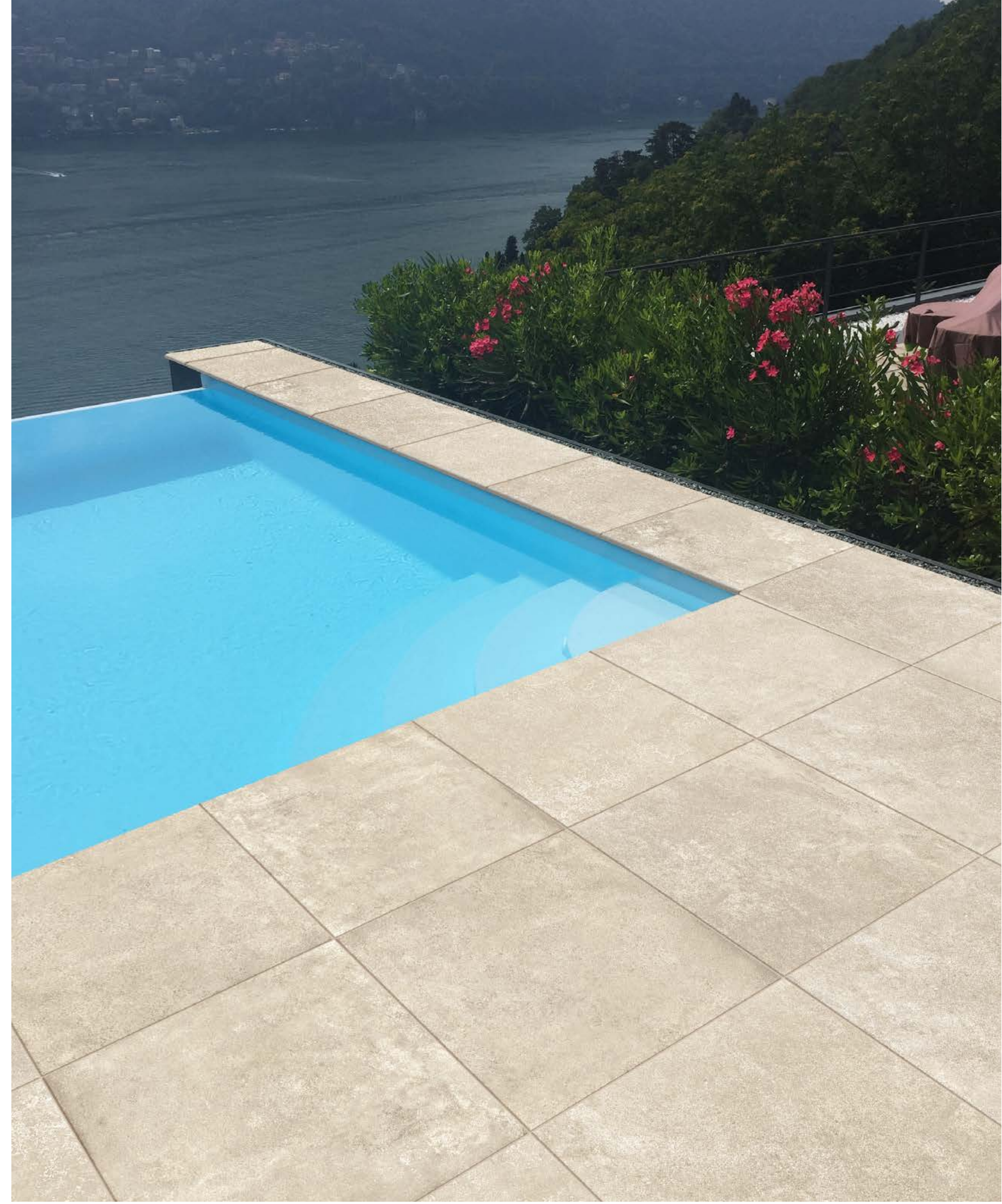

II. What are PORCELAIN PAVERS?

A Porcelain Paver is an extra-thick porcelain stoneware slab.

Kronos's structural porcelain pavers, along with POPA-Porcelain Pavers and SKE 2.0 ranges, provide unique benefits not available with other architectural paving options.

The porcelain pavers supplied by us are ¾" thick and feature exceptionally low maintenance, combined with outstanding stain resistance, scratching and no color fading. They are affordable, light-weight, frost-proof, non-slip, flame-resistant, heat-insulating and removable in those job where it is not installed with thin-set or glue.

INTENDED USE

- The top-quality technical performance of the Porcelain paver, creates a free-standing and unglued floor featuring a realistic and excellent aesthetic value without any additional processing such as reinforcement.
- Designed for both **commercial high-traffic and residential applications**, pavers can be used with adjustable-height pedestals for raised decks, laid over hard surfaces such as concrete or on compacted sand or gravel.
- They are ideal both for residential outdoor uses, such as patios, terraces, gazebos, swimming-pools, gardens, garden paths, stairs, balconies, driveways and roof tops. As well as for commercial outdoor uses such as the outside areas of bars, restaurants, spas, swimming-pools, beach resorts and walkways.

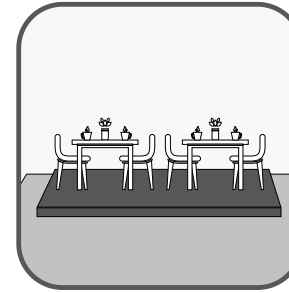

Sidewalk cafes

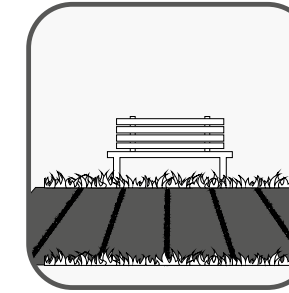

Walkways and pathways

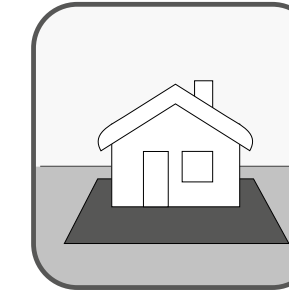

Gardens and patios

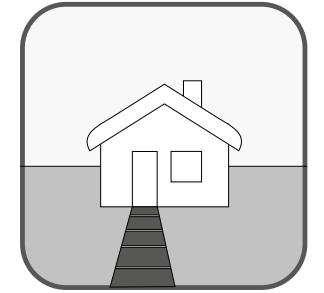

Garden paths

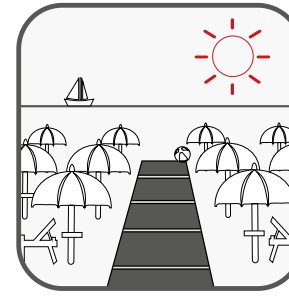

Beach resorts

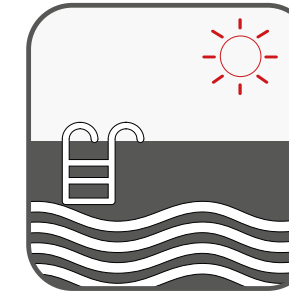

Swimming-pools

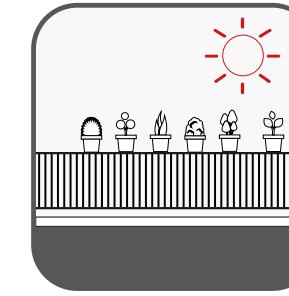

Terraces and balconies

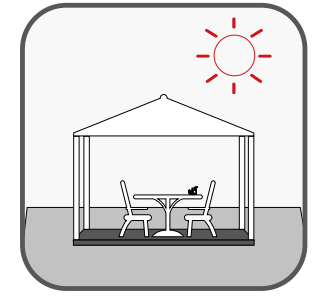

Gazebos

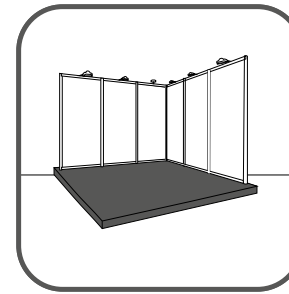

Exhibitions and events

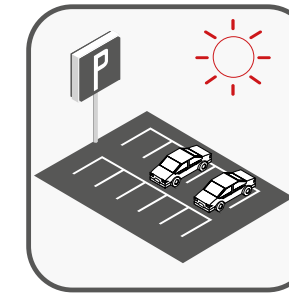

Public parks

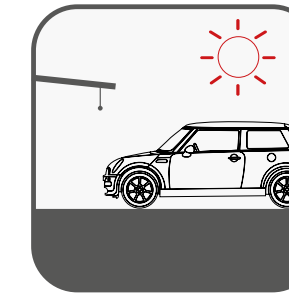

Public parkings

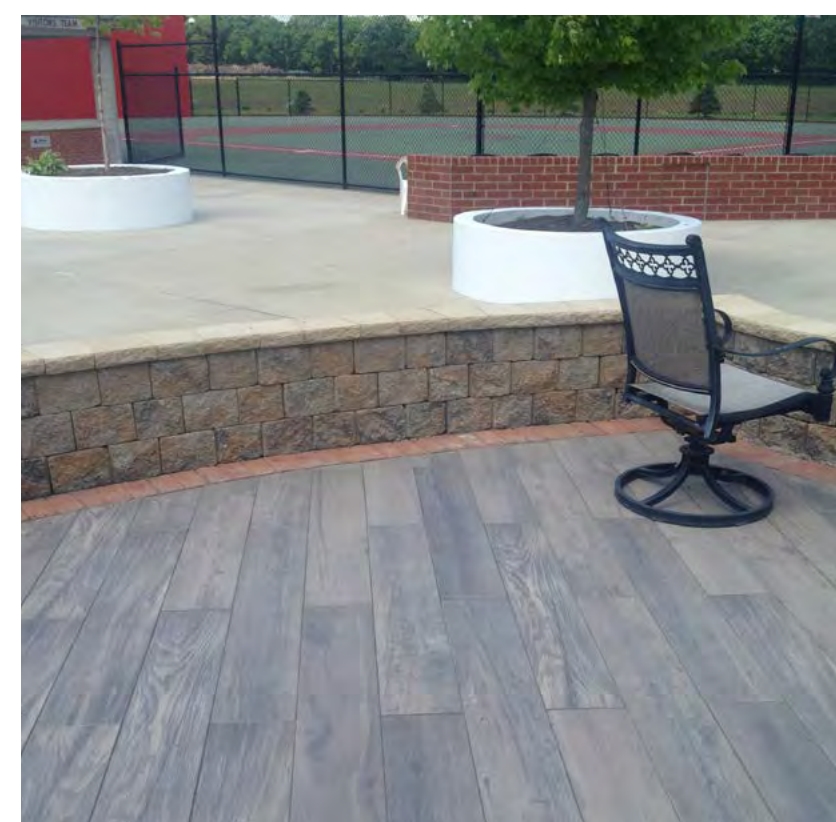
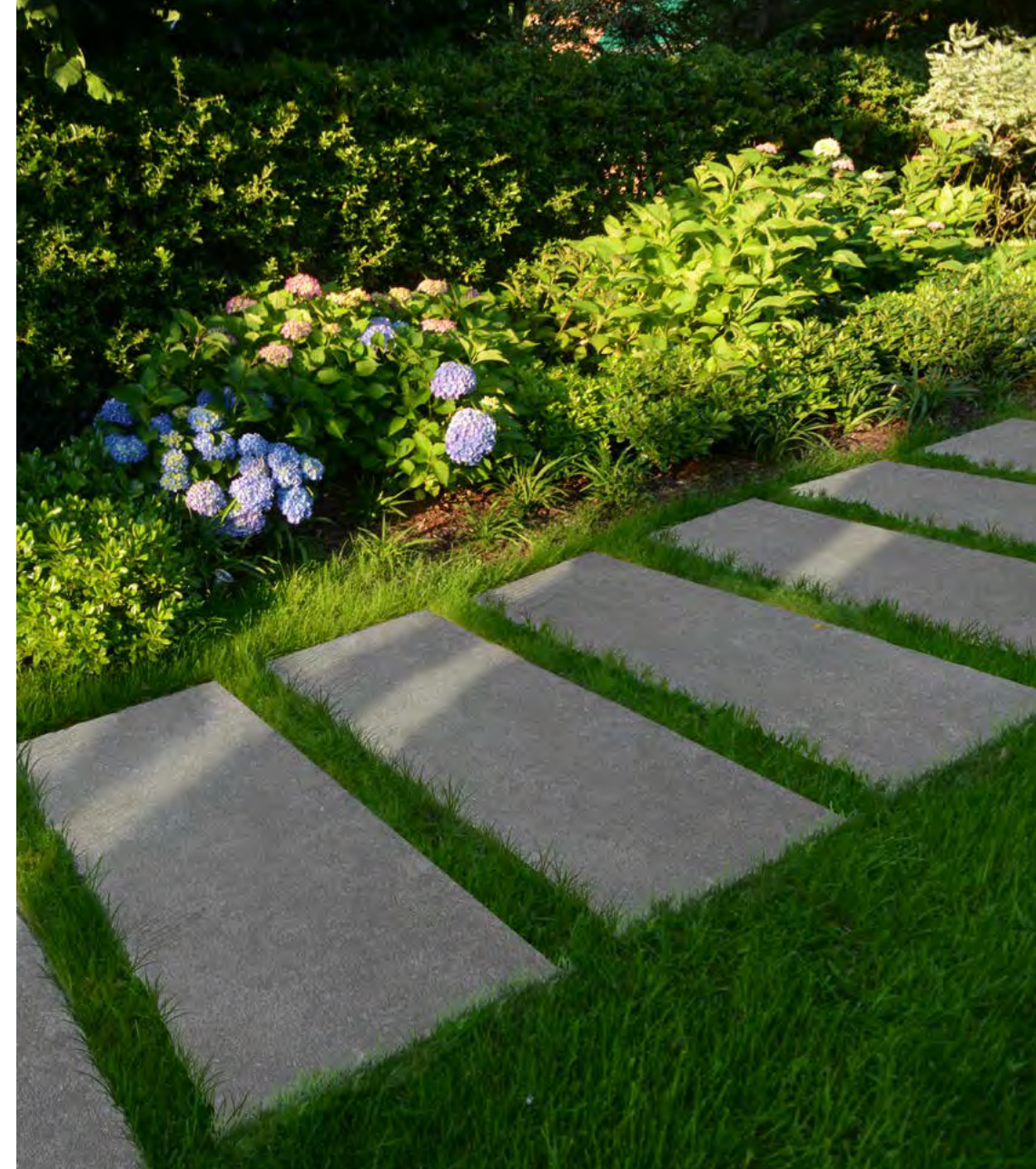

III. Why choose 2 CM?

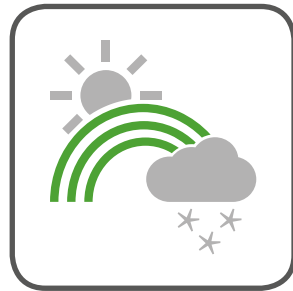

Thermal shock resistant. (-40°F - 210°F)



Superior in fire resistance and durability to wood tiles



Easy to clean. Stain, chemical and salt resistant

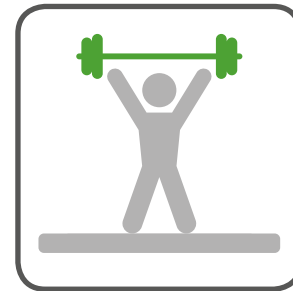

Superior in strength and impact resistance to ceramic tiles (supports over 2000lb), lighter and easier to handle than concrete blocks

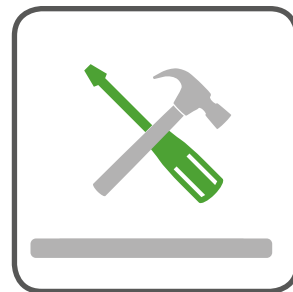

Virtually no maintenance



Slip resistant and quick draining

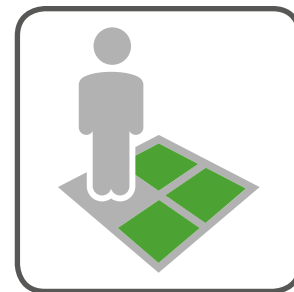

Easy to install



Removable and reusable POPA 2.0 is ideal both for temporary flooring and for permanent flooring

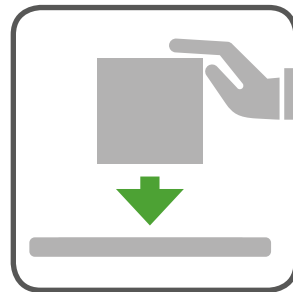

Versatile installation. Various installation methods including pedestal set, gravel and grass set. They offer endless opportunities for landscape design creativity in both domestic and commercial applications.

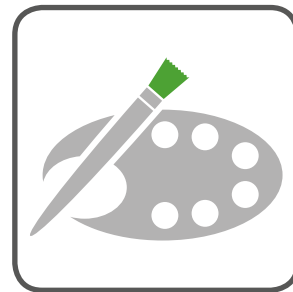

Fade resistant



Available in a broad range of colors/styles

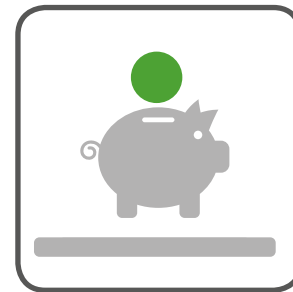

Massive over life cost savings more cost effective than grating or grid structures for elevated paving installations

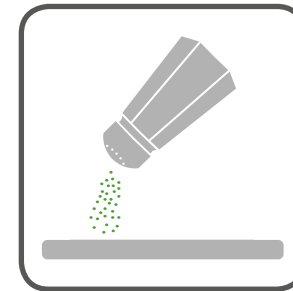

Resistant to salt corrosion.

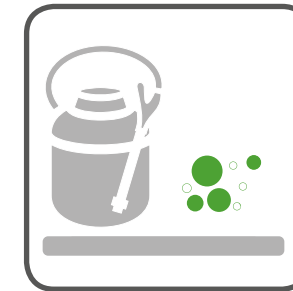

Resistant to attack from mould, moss and verdigris treatments.

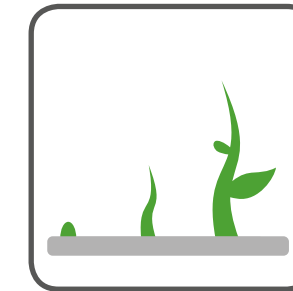

Resistant to efflorescence and other marks.

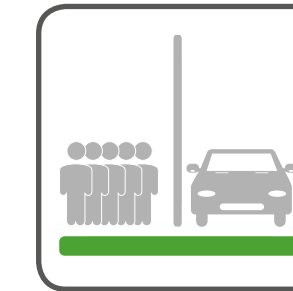

Durable: resistant to heavy vehicle and pedestrian traffic.



Frost-proof.

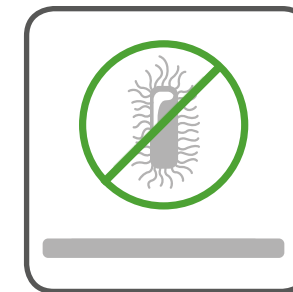

Hypoallergenic. No VOC.



Easy to sterilize.

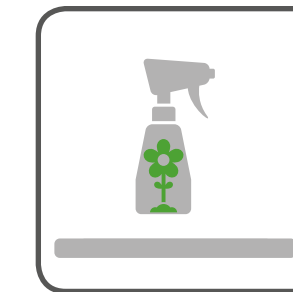

Eco-friendly maintenance.



Easy to clean.



Recyclable and ecological.



New solution in extra-thick porcelain stoneware for outdoor trilling. 2 cm thick, colored fine porcelain stoneware slabs obtained from atomizing high-class clays, quartzes and metal oxides pressed at 400 kg/cm², completely sintered at a temperature of 1200°C and then squared using a system of abrasive grinders.

IV. OUTDOOR 2CM - 3/4" RANGE

POPA 2.0

Porcelain Pavers
Made in USA

- 1. 60x60 - 23½"x 23½" USA stock
- 2. 60x30 - 23½" x 11¾" special order
- 3. 30x30 - 11¾"x 11¾" special order

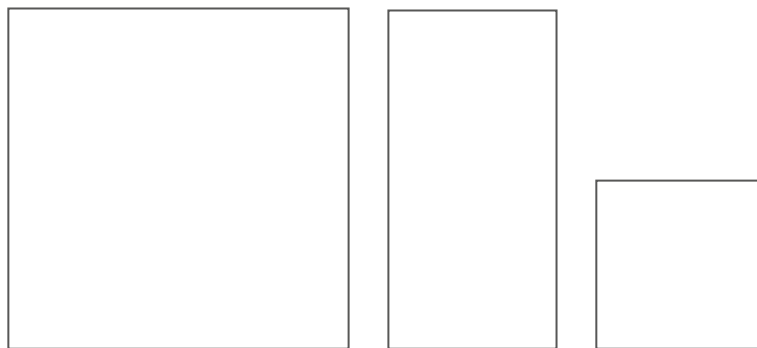

1. 2. 3.

2.0 slabs are all levelled. State-of-the-art technology ensures excellent precision in terms of sizing.

The sizes indicated in the catalogue refer to the actual sizes of the slabs, subject to the minor tolerances allowed by the industry regulations.

Furthermore, the sizes match those of tactile flooring for the visually impaired.

SKE2.0

Porcelain Pavers
Made in ITALY (special order)

- 1. 60x60 - 23½"x 23½"
- 2. 60x120 - 23½"x 47"
- 3. 20x120 - 7⅞"x 47"
- 4. 40x120 - 15¾"x 47"
- 5. 30x240 - 11¾" x 94"

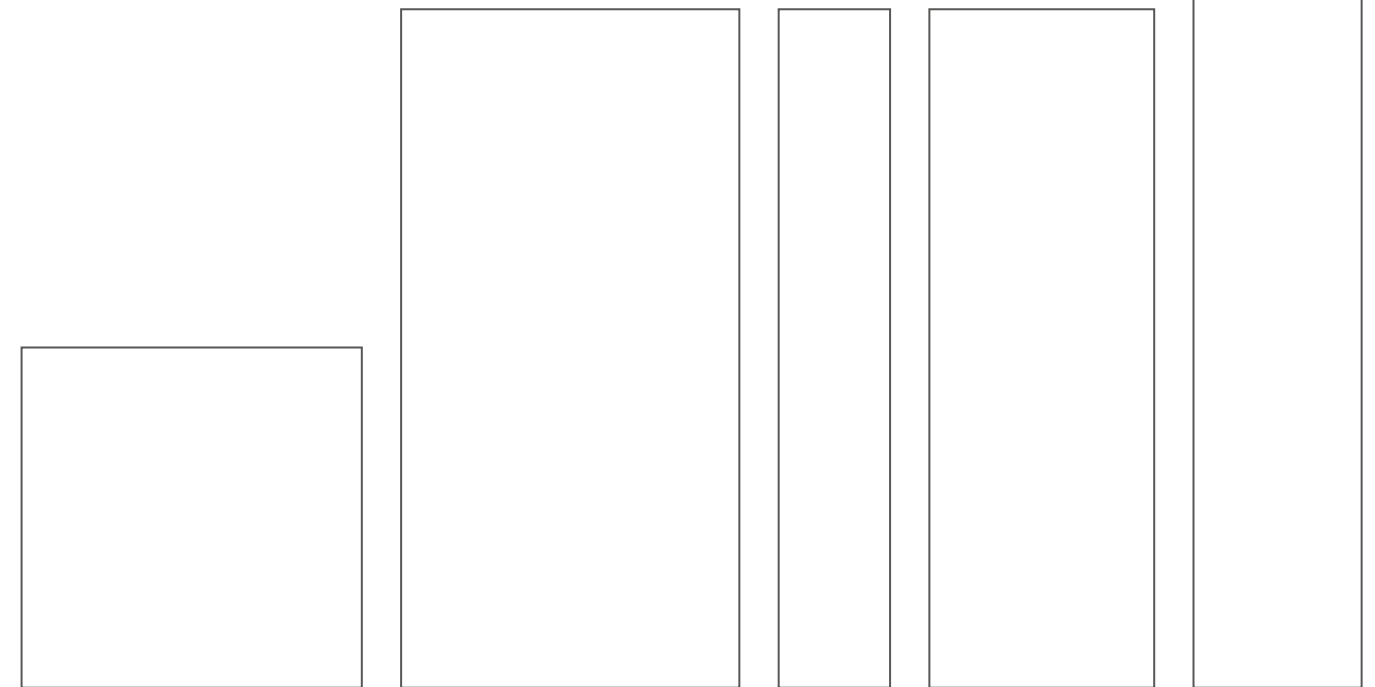

1. 2. 3. 4. 5.

V. TOOLS & HANDLING

CUTS AND HOLES

- It is possible to cut the material both in damp or dry conditions.
- It is essential to use ONLY specific diamond cutting wheels for porcelain stoneware.
- To make holes in the slabs, use diamond drill bits for porcelain stoneware.



DRY GRINDING MACHINE



10" T3 RAZOR DIAMOND BLADE



TPE 230 TILE CUTTER



CUTTING PORCELAIN PAVERS

The following notes are based on personal experience. We would welcome hearing from anyone who may have additional comments or information to share.

Diamond wet saw blades will always give a better result than dry cutting. Most diamond blades however do not seem to have particularly long life when cutting 3/4" porcelain pavers and so far, only two blades stand out from the rest - the Hot Frog and Razor or Razor T3.

The following are brief comments on a few blades tested.

Hot Dog - The longest lasting blade tested so far with over twice the life of most other blades except Razor. Seems to cut with less effort than other blades. Sold by e.g. ContractorsDirect.com.

Razor - Very good life but possibly slightly less than Hot Frog blades. Cuts quite quickly. Probably leaves a slightly rougher cut edge than e.g. MK415 blades. Razor T3 is reported to be even better, but is only available in 10" size. Imported by RTC Trading and sold by e.g. ContractorsDirect.com.

Porcellana - Quite good performance in terms of speed of cutting and clean cuts at the beginning, but fades very rapidly and then becomes impossible to cut pavers, even slowly.

Pearl - The only sample tested gave a poor performance with a very short life.

Terminator - A thicker blade which did not work satisfactorily because it chipped the pavers very badly.

MK Model 415 - One of the better blades tested. Gives a nice clean cut without chipping but only about half the life of the Razor blade. (Seems to be subject to some potential quality control issues as the first blade used was not perfectly round). No other models in the MK range have been tested.

Norton Clipper Slicer 7696 - Initially appeared to be a very good blade with

a lifetime equivalent to the Hot Dog (although slower in cutting) and a smooth cut. But after receiving two blades which were not perfectly round and thus tended to chip the underside of the beginning and end of a cut, we have some doubts about their quality control. Also working with this blade needed more patience in cutting as attempting to cut too quickly, could seize the blade especially if the paver had been left exposed to hot sun.

De Walt or Bosch - blades not tested.

Some other hints:

- A bridge saw is much easier to cut these heavy pavers since you are pulling the saw blade across the paver instead of pushing the paver into the saw blade.
- An 8" bridge saw works OK but a 10" bridge saw with a higher horsepower motor would be preferable for large jobs.
- Thinner blades seem to be better than thicker blades, especially in terms of cleaner cuts.
- When cutting darker pavers in particular, avoid cutting the pavers if they have been lying in full sunlight and are quite hot. If using a wet saw, it seems that the water causes some differential cooling across the paver as you are cutting. When the blade is half to 3/4 across the paver, the cut line tends to close up a little and can cause the blade to jam - and trying to extract a jammed blade from a bridge saw is not easy.
- A blade that is becoming worn will tend to 'wander' across a 24" cut resulting in a bowed cut rather than a perfectly straight line.
- It's worth purchasing a dressing stone which is designed to sharpen and reactivate diamond blades. These stones cost about \$10-\$15 and do indeed appear to prolong the life of the blade somewhat.

HANDLING

- To install and remove the slabs, it is advisable to use the special tools (paver clamps) supplied by us.

PROTECTIVE PACKAGING

- Porcelain pavers are protected by cardboard packaging material. Do not remove this protection until it is time to lay the slabs.
- In order to avoid the risk of chipping the slabs, do not pile them loose / out of the box on top of each other or handle them without the protective cardboard either then when you're ready to finally lay them.

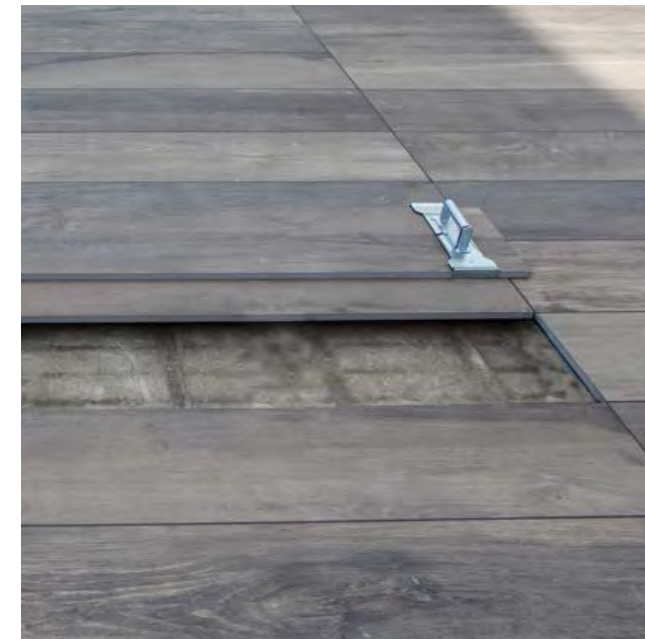

LIFTING CLAMP

Available in different sizes according to slab sizes (60x60, 20x120, 40x120).

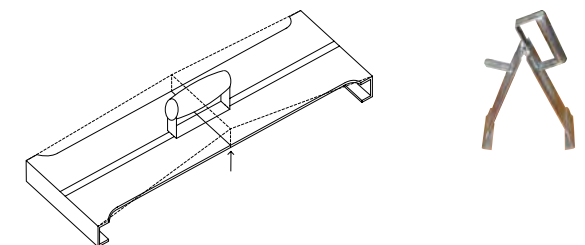



INSTALLATION OPTIONS

- 20 **COMPULSORY GENERAL INDICATIONS APPLICABLE TO ALL CASES (A1 TO A5)**
- 21 **A- LAYING DIRECTLY WITHOUT ADHESIVE – PEDESTRIAN USE**
- 23 A1 - DRY LAYING ON SAND, ON A COMPACTED GRAVEL SUBSTRATE (ROAD BASE)
- 24 A2 - DRY LAYING ON A DRAINAGE SUBSTRATE
- 30 A3 - DRY LAYING ON A CONCRETE PLATFORM
- 31 A4 - LAYING "ORIENTAL GARDEN" STYLE
- 32 A5 - LAYING WITH FIXED PEDESTALS ON A CONCRETE PLATFORM
- 34 **B - LAYING WITH ADHESIVE – FOR LIGHT-WEIGHT VEHICLES**
- 36 B1 - LAYING WITH GLUE ON A CONCRETE SCREED
- 37 B2 - LAYING WITH ADHESIVE ON A FULL MORTAR BED

COMPULSORY GENERAL INDICATIONS APPLICABLE TO ALL CASES (A1 TO A5)

SUBSTRATE

- Level the substrate and compact it with care before proceeding with installation consisting of resting the slabs on the substrate.
- It is advisable to lay a separating cloth (geotextile) to stabilise the substrate in order to limit any washing away along the gaps/joints between the pavers and to minimize the growth of weeds and possible dens of insects in between the joints.
- In the event of a sandy substrate, before compacting it, make sure that the level of moisture of the sand is sufficient to guarantee the best possible compacting.



SPACERS BETWEEN PAVERS

When laying porcelain pavers by resting them directly on the substrate, they **must never be laid so that they touch each other**, as this would drastically increase the risk of chipping caused by micro-movements while the pavers are settling into place.

- **Always** use plastic spacers for gaps of 3/16" (4 mm), available with X and T-shapes.
- When using **plastic pedestals** (cases A2 and A6) the spacer is already included in the plastic support.



DO NOT USE A PLATE COMPACTOR AFTER LAYING

To avoid any risk of chipping the material, never use a plate compactor once the porcelain paver slabs have been laid.



X-SHAPED SPACER

T-SHAPED SPACER

EDGE RESTRAINTS

When pavers are laid on draining sand or gravel, always prepare an edge restraint system to hold the substrate material used and prevent any washing away of sand or gravel, therefore keep the paver slabs in place. It is possible to use different types of restraint systems:

- invisible edging, lower than the thickness of the slab plus that of the base; this must be suitably fixed to the ground.
- visible edging, with a strip of concrete, stone, porcelain stoneware or other material.

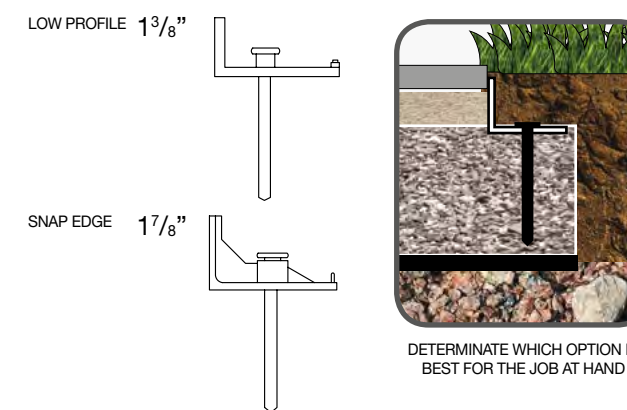

DETERMINE WHICH OPTION IS
BEST FOR THE JOB AT HAND

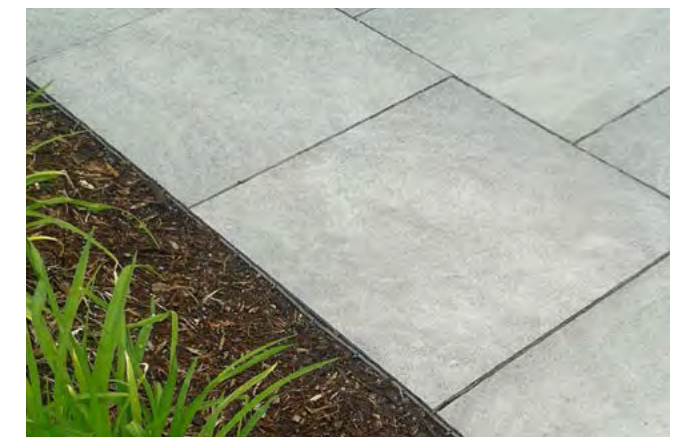

SUBSTRATE

To ensure the necessary stability in time, **the area provided as a substrate must always be larger than the actual paved area**. Its size will have to be defined depending on the type of substrate used and on the characteristics of the site. Generally speaking, an extra space of about 8 to 9" on each side is sufficient.

SLOPES AND DISTANCES FROM BUILDINGS

In order to prevent water from collecting and to facilitate drainage, the surface must always have the appropriate slope, the extent of which has to be defined on the basis of the specific features of the site and on a job to job basis (indicatively, 2° degree). It is advisable to leave a suitable draining distance between the paved areas and any building wall.



MATERIAL FOR FILLING THE JOINTS BETWEEN THE PAVERS.

In the case of pavers resting on the ground, there are several solutions for filling the gaps between them.

LAYING ON SAND

- Fill the gaps between the pavers with sand and eliminate the excess material. In time, rain, wind and cleaning activities may remove the sand, therefore calling for some occasional re-filling when necessary.

LAYING ON SAND WITH ADDED CEMENT

- Prepare a dry mixture of sand and cement (indicatively the cement will be $\frac{1}{4}$ of the total) and fill the gaps between the pavers with it.
- Eliminate any excess material carefully, making sure that none remains on the slabs.
- Lastly, wet the gaps with water so as to consolidate the filling material by activating the cement contained in it.

LAYING POLYMERIC SAND OR GRAVEL

- Polymeric sand is a composition created specifically for making joints in outdoor paving. It is important to use specific sand for porcelain stoneware (which absorbs small quantities of water). This sand, available in several different colours and grain sizes, has polymeric substances that bind together in the presence of water added to it.
- Once the polymeric sand has been compacted, it will prevent the growth of weeds and the removal of the filling material by the action of rain and wind or due to cleaning activities.
- Once the gaps have been filled with polymeric sand, eliminate with great care all the excess material, removing any residues of sand from the surface, even using mechanical blowers.
- Lastly, wet the gaps between the pavers with water to activate the reaction of the polymers that will transform the sand into a compact body.

POLYMERIC SAND OR GRAVEL



A1. Dry laying on sand, on a compacted gravel substrate (road base)

With the following illustrations we show a cross-section of a typical installation.

In practical applications, all the considerations will have to be reviewed by a qualified and experienced professional staff in relation to the specific nature of the site and to the regulations in force at the site.

- Prepare a **substrate** about 8" to 10" wider than the perimeter of the paved area. The paved area must remain at a distance from any buildings.
- Compact the substrate and lay a **separating cloth** (geotextile) to stabilize the substrate, limit the removal of material from the gaps between the pavers and minimize the occurrence of plants or insects.
- Always insert a **restraining edge**, fixing it suitably to the substrate in accordance with the manufacturer's indications depending on the type of material used for the substrate
- It is advisable to arrange an approx 2° degree slope for the flooring.
- Always use plastic spacers for the 3/16" spacers in between slabs, inserting T-shaped spacers around the edges.

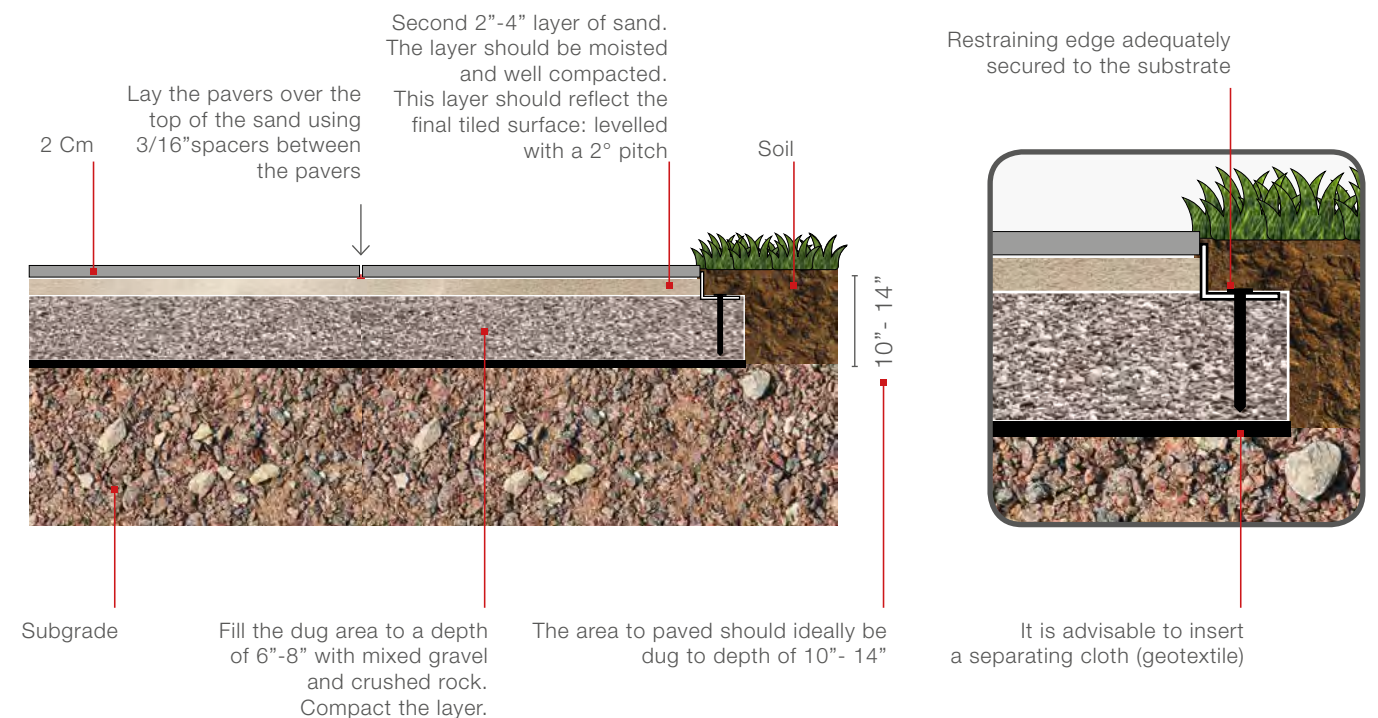

A2. Dry laying on pedestrian drainage gravel

With the following illustrations we show a cross-section of a typical installation.
 In practical applications, all the considerations will have to be reviewed by a qualified and experienced professional, in relation to the specific features of the site and to the regulations in force at the place concerned.

- Prepare a **substrate** about 8" to 10" larger than the perimeter of the paved area on all sides. The paved area must remain at a distance from any buildings.
- Spread a ¾" thick layer of draining gravel (¾" thick open-graded aggregate). Compact the substrate and arrange separating material (geogrid) over it to stabilize the substrate and to secure the restraining edge in place.
- Prepare the **restraining edge**, fixing it suitably to the substrate in accordance with the manufacturer's indications depending on the type of material used for the substrate (drainage gravel).
- Make sure that the upper surface has about 2° degree slope.
- Always use plastic spacers for the 3/16" wide gaps between the pavers, inserting T-shaped spacers around the edges.

The thickness of the various draining layers has to be defined on the basis of the conditions of the ground and of the specific features of the site.

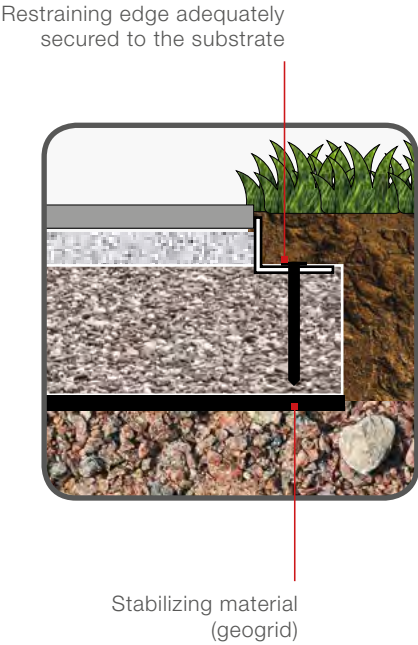
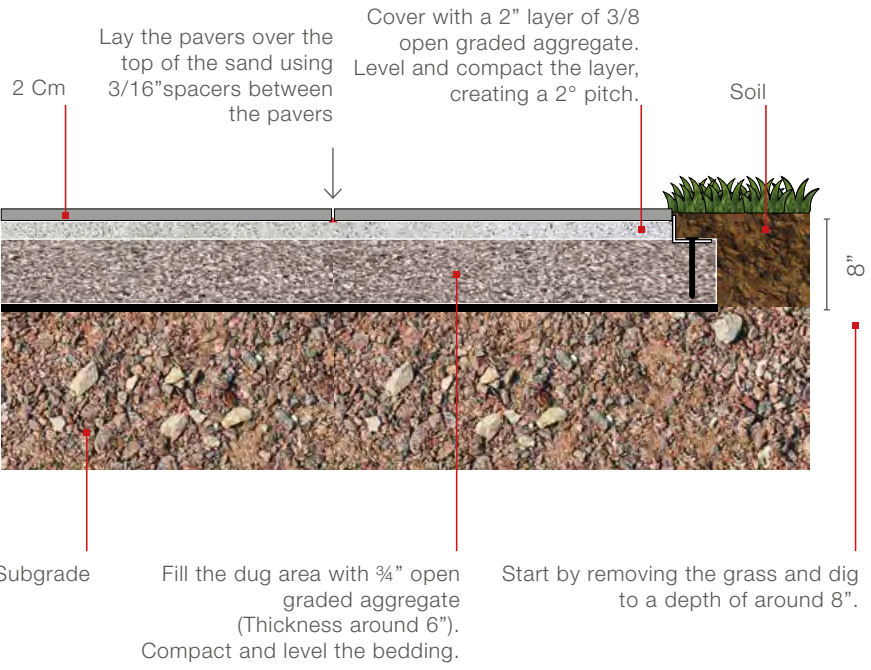

Alternative laying with Euro Base panels



Euro Base panels, ¾" thick, can be used to replace a 6" layer of pressed gravel.
 They are usable immediately.

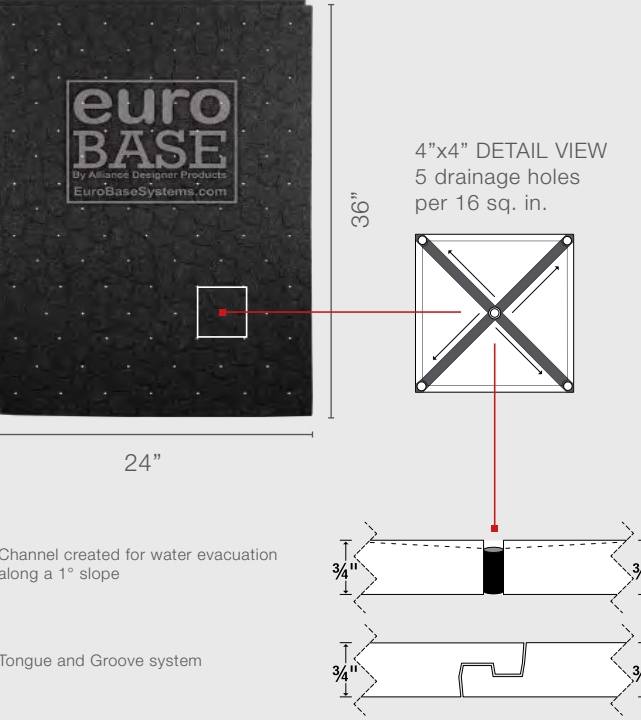

- Save 6 inches of needless excavation
- Save 6 inches of crushed stone
- Save the cost of truck and driver on the road
- Save on costly dumping fees
- Save wear and tear on machinery
- Save on labor costs
- Save overall installation time
- Increase profit
- For pedestrian use only

Features

- Built to Last
- Better Load Transfer
- Better Freeze and Thaw Protection

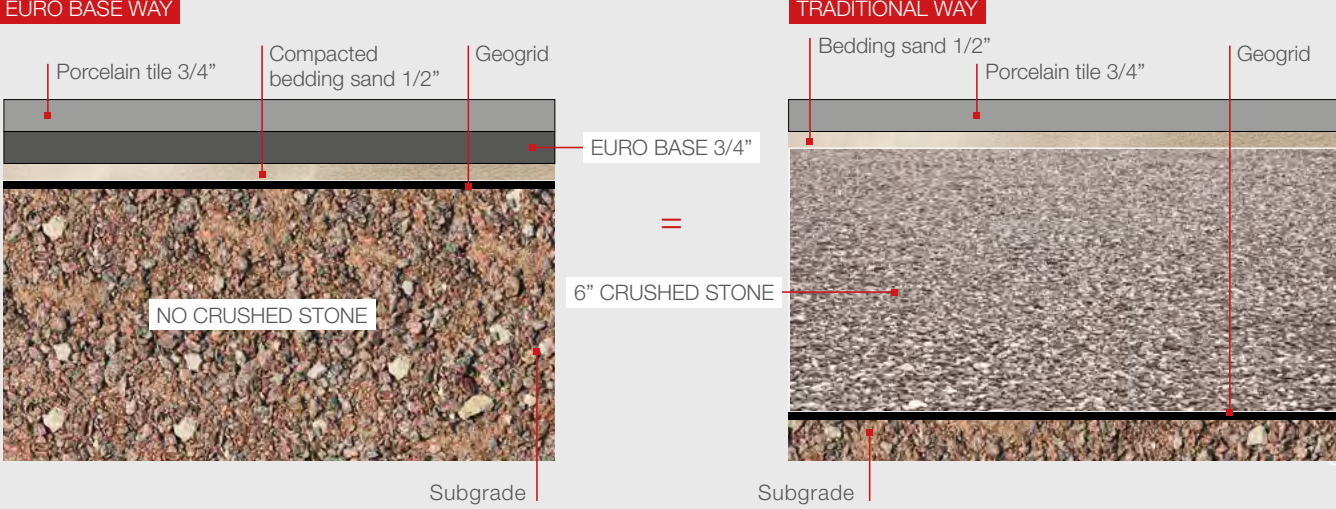

MORE INFO: www.eurotile.com/products/euro-base

EURO TILE EDGE

The Euro Tile Edge is the fully customizable solution to run around the perimeter of your finished porcelain tile installation, providing stability and strong lateral support. The Euro Tile Edge is made with 100 % polyethylene.

Features

- Will not corrode.
- Easy-to-use.
- Xtra versatile.
- Xtra robust system.
- Xtra support strength.
- Use with Euro Tile Screws.



EURO TILE SCREWS

Fastening Euro Tile Edge with the Euro Tile Screws through the Euro Base reinforces the outside perimeter, creating a strong lateral support.



1. Euro Tile Edge
2. Euro Base
3. Bedding Sand
4. Geo-Fabric
5. Native Soil

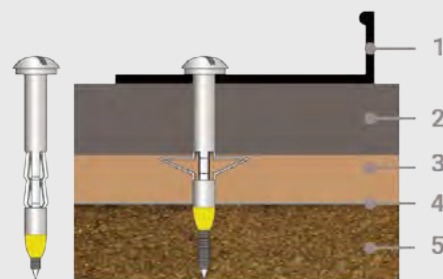

EURO TILE SPACER

The creation of the Euro Tile System allows for the installation of porcelain tile directly on top of the Euro Base using the **Euro Spacer** to provide uniform spacing and unparalleled stability. The Euro Spacer has been designed to provide the right support, load transfer and a monolithic structure binding all units together.

All Euro Spacer bars can be removed to create a flat disk to support larger tiles and uniformize the load transfer to all units. Simply break the spacer bar's bridge to obtain a flat disk.

The spacer can be cut into either a half- or a quarter-unit to be used along the edge of a building or the Euro Edge. Take note that the spacer bar needs to be kept to ensure exact spacing when laying the tile.

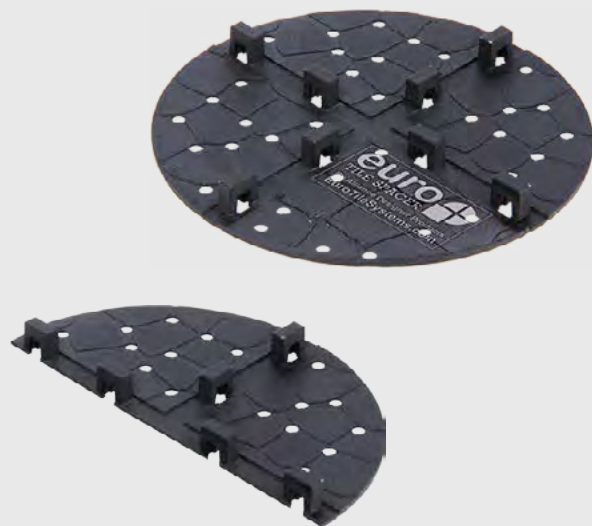

Euro Tile Bond Adhesive can be used on dry or humid surfaces. It ensures mechanical binding and structural integrity of the system. Binding the Euro Tile Spacer to the porcelain tile minimizes any lateral or vertical movements.

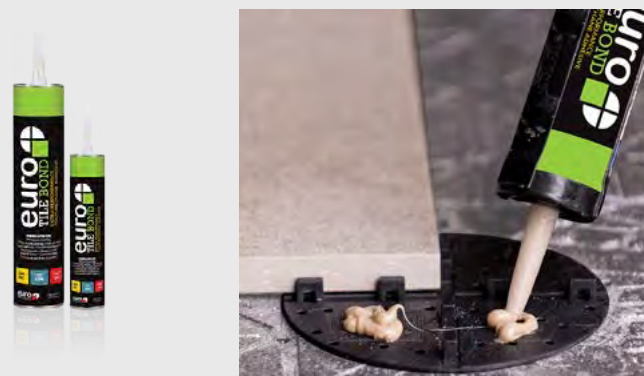

MORE INFO: www.eurotile.com/

Photogallery and video tutorial: www.eurotile.com/media/

EURO TILE POLYMERIC SAND

Euro Tile Sand is a unique mixture of polymer binders and calibrated sand available in Beige, Slate Grey, Ivory and Black Diamond.

Once Euro Tile Sand sets, it becomes very firm and locks between the tile joints while still retaining flexibility and providing a long lasting, durable jointing material.



Features

- Can be used for joints up to a maximum of 1 inch (2.5 cm) and its fine gradation allows use in even the tightest joints
- Helps prevent weeds and damage caused by burrowing insects
- Helps prevent erosion due to wind, rain, and freeze thaw cycles
- Fast setting: Product sets within one hour after application of water
- Sets at above freezing temperatures (32°F/ 0°C)
- Can be applied even if rain is expected (however, minimum of 1 hour of dry weather is needed after activation)
- Intact pallets can be stored outside

Ideal for pedestrian use such as:

- Patios
- Walkways
- Pool surroundings
- footpaths

4 BEAUTIFUL COLORS TO CHOOSE FROM



SLATE GREY BEIGE IVORY BLACK DIAMOND

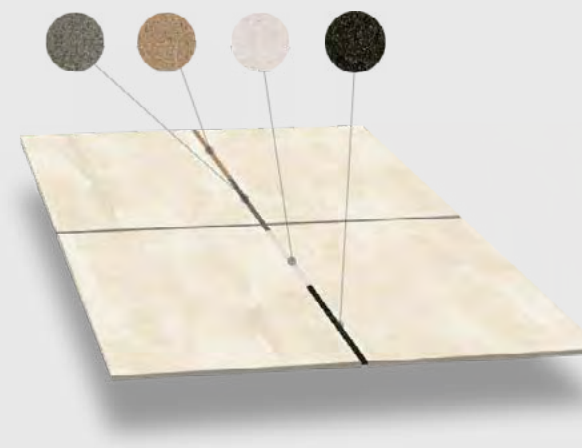

STRONG YET FLEXIBLE

SELF HEALING

**RESISTS FREEZE/THAW,
EXTREME HEAT AND EROSION**

**1 HOUR SETTING TIME,
SETS ABOVE 32°F (0°C)**

USING PUREST, CLEAREST POLYMERS

**STRONGER AND MORE
DURABLE POLYMERS**

CLEANER SAND GRADATION

MORE WATER REPELLANT

Installation summary

Stages of installation applicable to cases A1 and A2. Always check the manner of laying in relation to the requirements of each specific case.

- Installation with EURO Base panels: Follow the indications including points 3a, 3b and 3c.
- Conventional installation: exclude points 3a/3b/3c.



1 Excavation of the new area.



2 Levelling and compacting of the base



3 Addition of geo-fabric, levelling and compacted bedding sand

EURO BASE OPTION

MORE INFO: <http://www.eurotileystems.com/products/euro-base/>

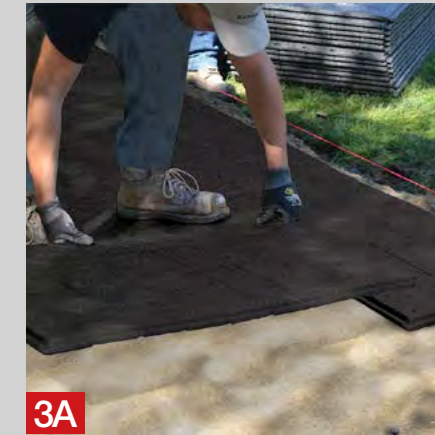

3A Installation of the Euro Base

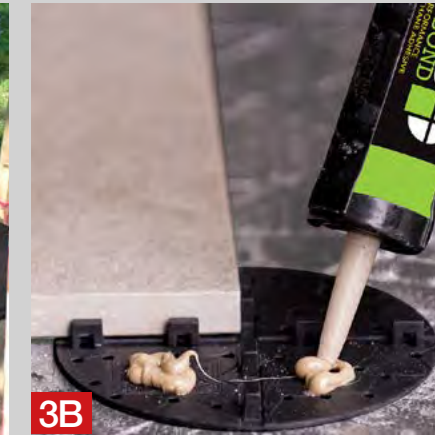

3B Installation of Porcelain tile and Euro Spacer



3C Installation of Euro Tile Edge and Euro Base Screws

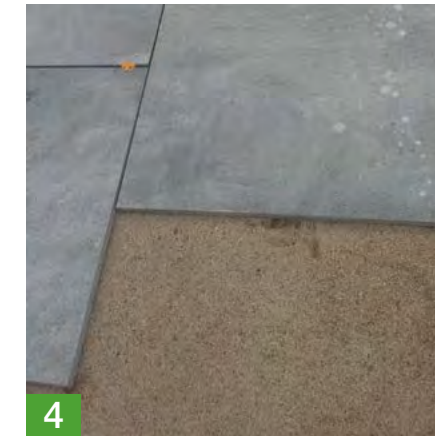

4 Installation of porcelain tile and spacer

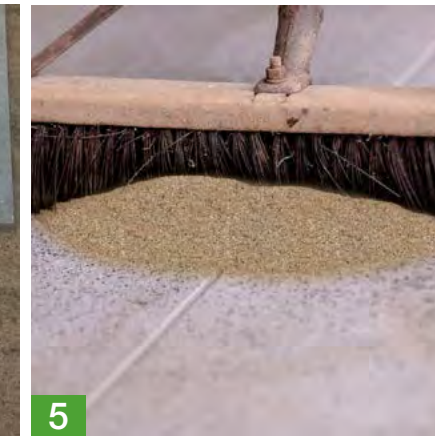

5 Sweeping, compacting and blowing of the tile sand.

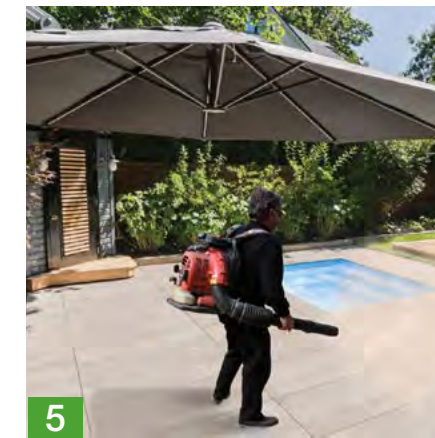
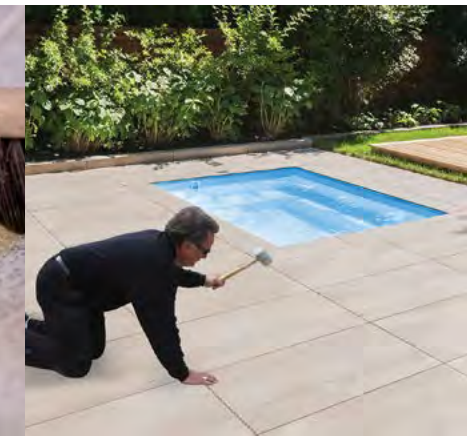

6 Shower and rinse simultaneously, so as to eliminate any sand residue.



A3. Dry laying on a (pedestrian) concrete platform

With the following illustrations we show a cross-section of a typical installation.

In practical applications, all the considerations will have to be reviewed by a qualified and experienced professional, in relation to the specific features of the site and according to the regulations in force at the specific job site.

- Prepare a **substrate** about 6" wider than the perimeter of the area to be paved. The paved area has to remain at a distance from any buildings.
- Make sure that there are no substantial / structural cracks in the concrete surface that would compromise its stability.
- It is advisable to arrange for the upper surface to have a slope of about 1° to 2°.
- Install an **restraining edge** of an adequate height, fixing it to the substrate.
- Cover the concrete surface with a **separating sheet** (geotextile) to limit the washing away of the layer of sand.
- Always use plastic spacers for the 3/16" joints between the pavers, inserting T-shaped spacers around the edges.

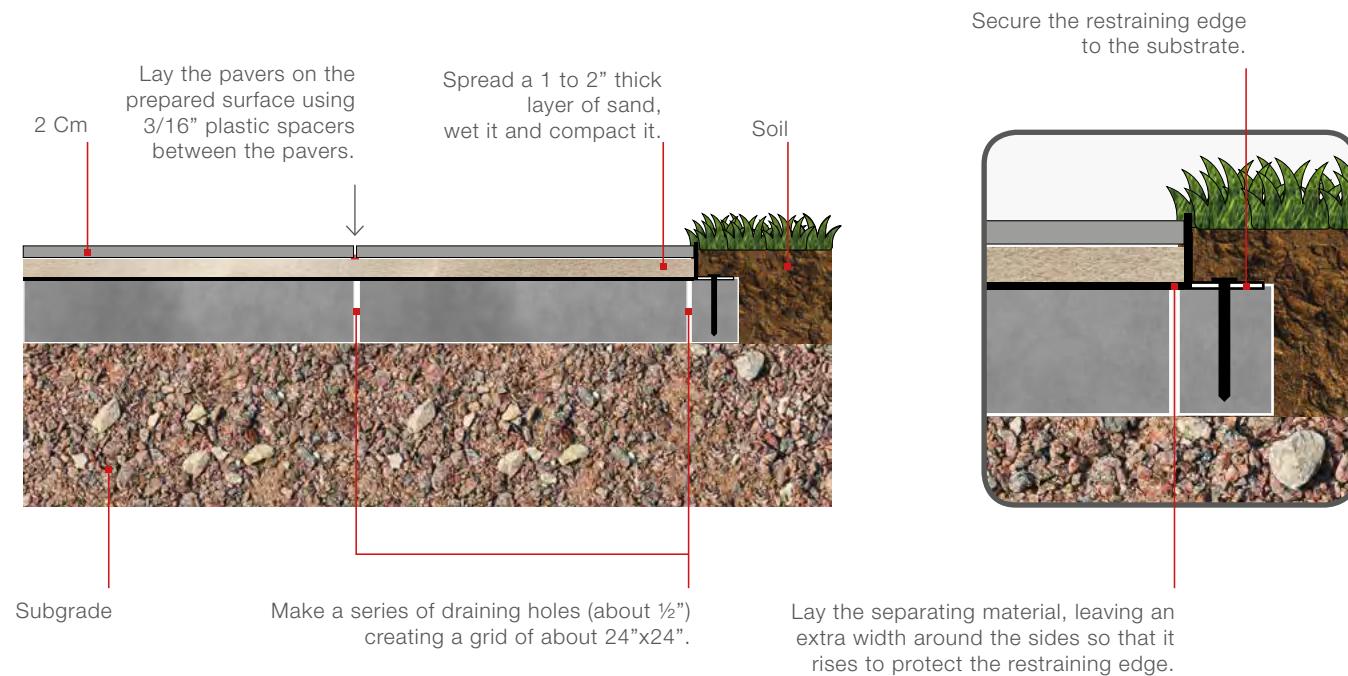

A4. Laying "Oriental Garden" style, directly on lawn (for pedestrian use)

With the following illustrations we show a cross-section of a typical installation.

In practical applications, all the considerations will have to be reviewed by a qualified and experienced professional, in relation to the specific features of the site and to the regulations in force at the place concerned.

- Lay out the pavers on the ground to determine the number of steps needed for the garden path, making sure the slabs are placed at equal distance from each other.
- Mark the perimeter of each slab with a spade and then remove the slabs.
- Remove the turf up to a depth of 5 cm.
- Create a stable and uniform bed using gravel.
- Lay the slabs so there is a fall of about 0.5 cm between the slab and the ground.
- Use a rubber hammer to bring the slabs to the same level of the turf.

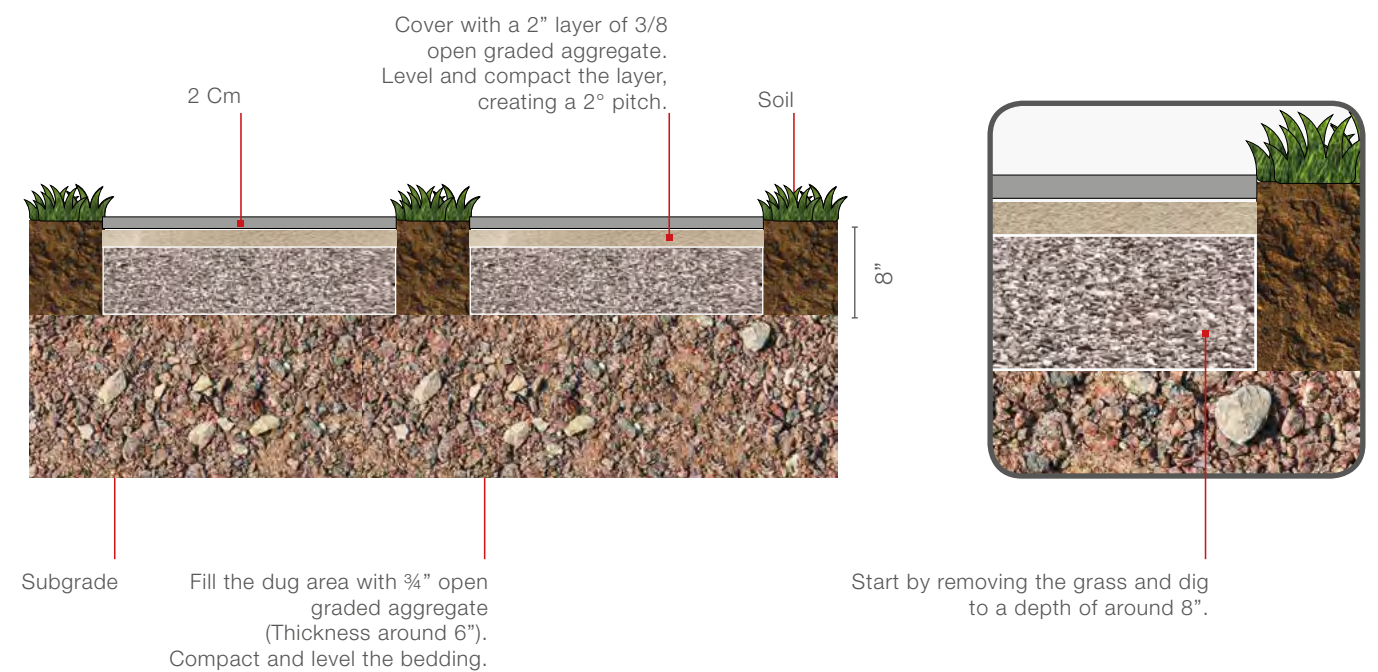

A5. Laying with pedestals fixed to a (pedestrian) concrete platform

With the following illustrations we show a cross-section of a typical installation.

In practical applications, all the considerations will have to be reviewed by a qualified and experienced professional, in relation to the specific features of the site and to the regulations in force at the place concerned.

- The concrete surface must be stable and flat and have a 2° degree slope.
- Make sure that the plastic pedestal supports are installed on all the corners of the installed pavers.
- When laying pavers over existing concrete, fixed-height support pads (1/2" to 1" high) with built-in spacer tabs should always be used to offset any slight unevenness in the concrete slab or deck and to provide accurate spacing between the pavers.
- Although rubber support pads generally provide sufficient friction to prevent the pavers from moving, it is always recommended that the area to be paved should be surrounded by low retaining walls to restrict any lateral movement of the pavers.
- As an alternative, fix or glue the edge supports to the substrate.

Restraining edge:

It may be possible to construct a restraining edge with an L shaped profile of either aluminum or PVC. A couple of commercially available products that could be considered include:

- Permalock Asphalt Edge - the 'Asphalt Edge' (1" high) would be a more suitable height than the 1 5/8" high 'StructurEdge'
- Oly-Ola Edging Stone-Edge - PVC edging 1" high

Or you could simply purchase lengths of L shaped extruded aluminum profile which has the advantage that it can be anodized in different colors e.g. from:

- Extrude.A.Trim - anodized aluminum profiles

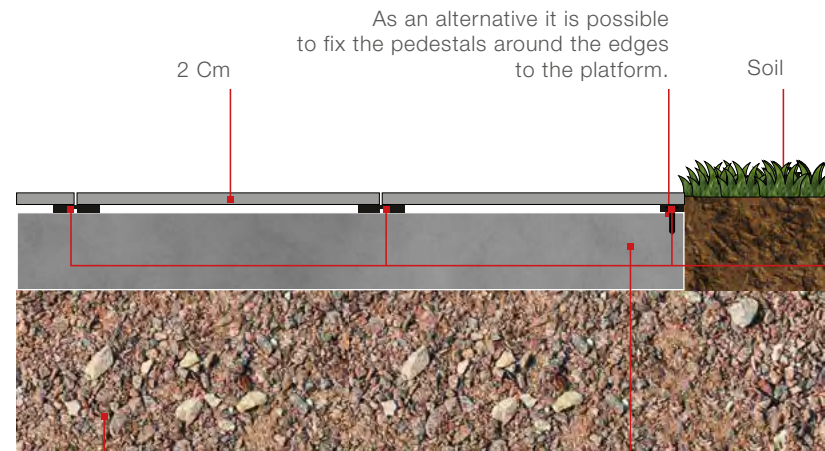

Concrete platform built with proper workmanship and complying with the regulations, in relation to the specific features of the site and to the type of traffic.

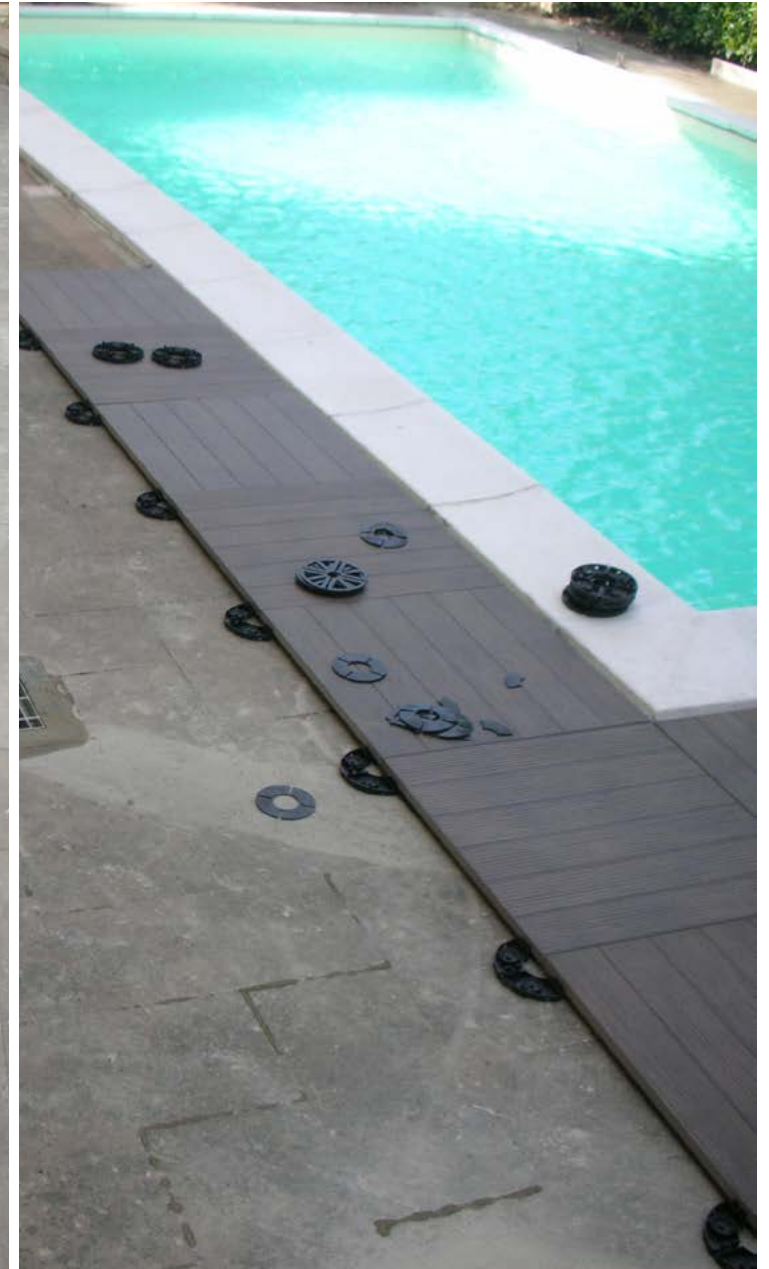

fixed height support pads (1/2" to 1" high)
The pedestals can be taken apart.



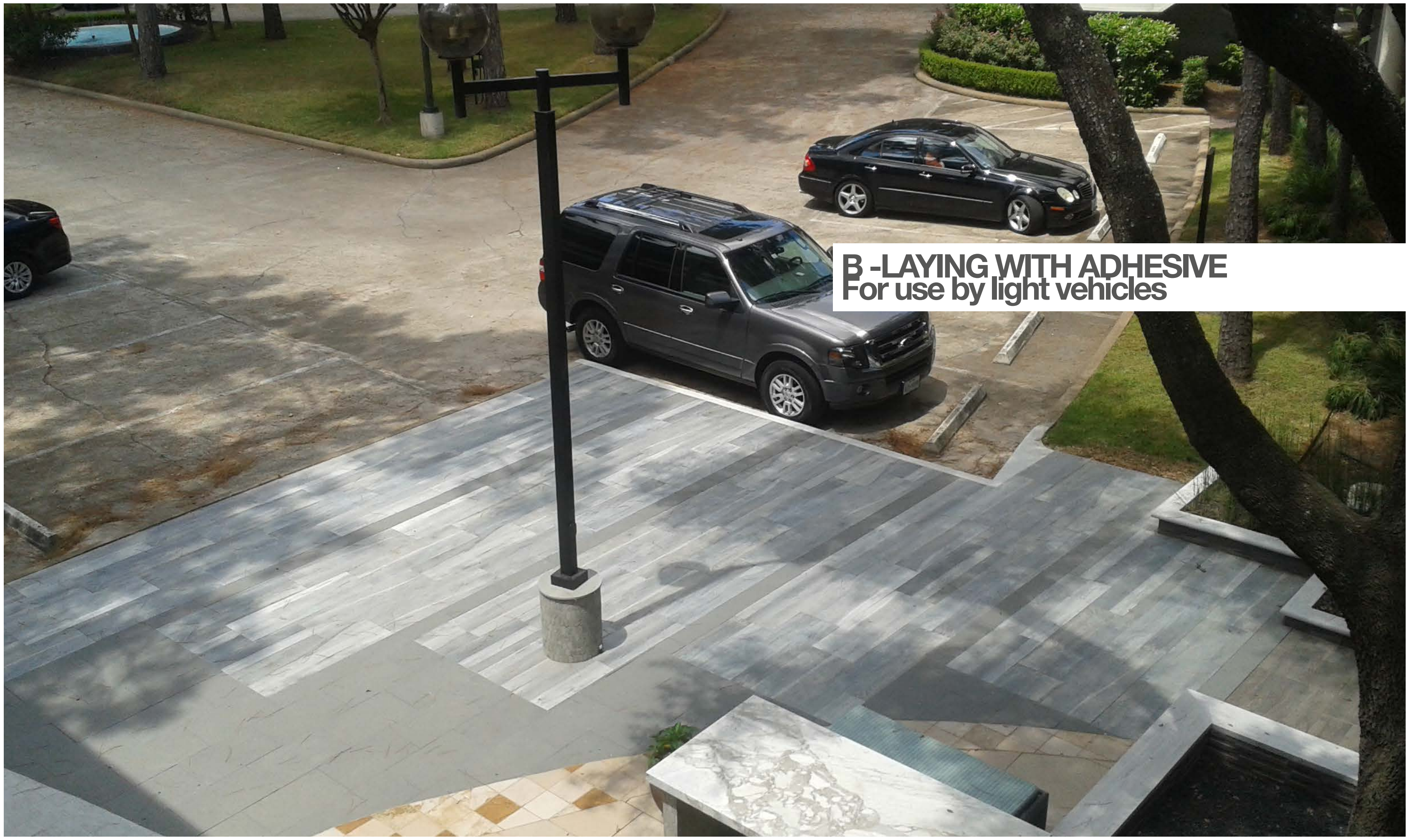

B -LAYING WITH ADHESIVE
For use by light vehicles

B1. Laying with adhesive on a concrete screed

- The concrete platform must be built with proper workmanship and structured adequately in relation to the specific features of the site, to the expected loads and type of traffic, in accordance with the standards of the American Concrete Institute (ACI) and the Portland Cement Association (PCA), and complying with the regulations according to ANSI A137.1 as well as in accordance to the regulations of the area where the job is taking place.
- Depending on the size of the paved area, it may become necessary to provide expansion joints in the underlying screed. It is essential for the screed joints to be created in correspondence of the joints of the ceramic slabs.
- Always use plastic spacers for the 3/16" joints, inserting T-shaped spacers around the edges.
- For the spaces between pavers corresponding to the expansion joints, gaps up to 3/8" wide may be necessary.
- Carry out careful cleaning after laying in order to remove all traces also, including those of glue as well as any joint-filling material.

ADHESIVE AND JOINT-FILLING MATERIAL

- Use only high-quality adhesives for outdoor laying of porcelain stoneware, making sure that they comply with the specifications according to ANSI A137.1
- As far as the specific indications and suggestions for the adhesives and joint-filling materials, comply with the manufacturers' indications referring to outdoor laying.

Some references for adhesives and filling materials for joints are indicated by way of example:

ADHESIVES

- <http://www.mapei.com/US-EN/Tile-&Stone-Installation-Systems/Flexible-Mortar-Systems/Kerabond-Keralastic-System>
- <http://www.laticrete.com.au/Products/MultipurposeAdhesive/tabid/603/Default.aspx>

JOINT-FILLING MATERIALS

- <http://www.mapei.com/US-EN/Tile-&Stone-Installation-Systems/Epoxy-Grouts/Kerapoxy>
- <http://www.mapei.com/US-EN/Tile-&Stone-Installation-Systems/Cement-Grouts/Ultracolor-Plus>
- <http://www.laticrete.com.au/Products/Grouts/EpoxyGrouts/tabid/609/Default.aspx>
- <http://www.laticrete.com.au/Products/Grouts/CementitiousGrouts/PERMACOLORGrout/tabid/660/Default.aspx>

Note:

When laying on a screed, it could be advisable to consider using a separating membrane.
http://www.schluter.com/schluter-us/en_US/

http://www.schluter.co.uk/media/552716_Heft_C_Konstruktionsaufbauten_Dachterrasse-GB_0513.pdf

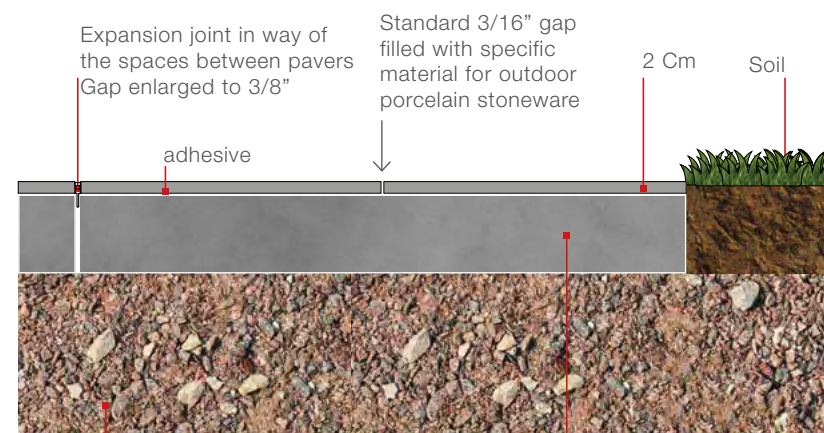

Subgrade

Concrete platform built with proper workmanship and complying with the regulations in relation to the specific features of the site and to the type of traffic

B2. Laying with adhesive on a full mortar bed

HEALTH AND SAFETY INFORMATION

During the construction process, safety procedures and safe working practices should be executed at all times, alongside the necessary protective equipment. The size of the paved area, it may become necessary to provide expansion joints in the underlying screed. It is essential for the screed joints to be created in correspondence of the joints of the ceramic slabs.

PAVEMENT DESIGN

For most domestic/private applications, the ground should be prepared and a sub-base of about 100mm, the most suitable for a patio, is dug out. The ground is then compacted and prepared based on the type of tile that will be installed.

EXCAVATION

For a correct installation of the new paving, the ground may require to be excavated to a certain extent. The depth of the excavation depends on the thickness of the mandatory sub-base, the sand and adhesive. In order to work out the correct depth for the excavation, the level of the finished surface must be at least 150mm below the Damp Proof Course to restrict problems of increasing damp in the structure.

EDGE RESTRAINTS

The edge restraints of the tiles must be adequately robust to prevent the lateral displacement from loadings placed on the paving surface, and are laid down before the sub-base installation. The edge restraints provide a steady vertical face to a level below the laying course material. When working with steep inclines or gradients, intermediate restraints should always be considered, their spacing is related to the severity/harshness of the incline.

SUB-BASE MATERIAL SELECTION

The granular sub-base material should be at least of Type 1 quality, any inferior quality may be bound to failure upon loading and prone to frost or moisture movement.

Materials incorporating organic matter are not recommended, while recycled materials, such as crushed masonry or concrete, as long as it is well graded and able to compact in order to give a close textured finish.

SUB-BASE CONSTRUCTION

The layers of the sub-base material should not exceed 75mm in thickness, it is recommended that each layer is fully compacted prior to the next layer being placed/deposited. In order to prevent migration of finer material, each surface must be clean and close textured when placed/deposited.

RIGIDLY LAID PAVING – MATERIALS SELECTION

It makes every effort in order to ensure the consistency in color and shade in our pavers, but it is inevitable for there to be some variation between different batches. It recommends mixing the contents of the packets in order to ensure an acceptable blend. When ordering further material at a later date, it is recommended to make a note of the shade reference number, making it easier to locate the appropriate material.

Porcelain Pavers are recommended to be installed on a full mortar bed and never on a five spot bed or alternative. /The installation of Porcelain Pavers is recommended on a full mortar bed, never on a five spot bed or alternative.

A full 'wet' workable mix mortar bed should support the pavers. The mortar bedding should have a thickness between 15mm and 30mm, furthermore a slurry primer or a similar bonding agent should be applied to the back of the paver to increase adhesion to the mortar bed and prevent separation. Adjustment may be necessary to ensure that the pavers are fully supported and do not move.

JOINTING

The width of the joints should be 5-8 mm wide and spacers may be used to obtain uniform joints. Every joint should be filled with polymeric sand. Dry or semi-dry sand/cement mixes must never be brushed into the joints, as it leads to the staining of the paving and is not a true rigid point. Before applying the polymeric sand in between the joints in a diagonal movement, the paved area should be saturated with water.

Important: To ensure the polymeric sand fills all joints to the entire depth and width, once the paving has been laid on the mortar bed, the excess mortar must be raked out with a suitable tool.

B2. Laying with adhesive on a full mortar bed

TIP

During the construction process, safety procedures and safe working practices should be executed at all times, alongside the necessary protective equipment. The size of the paved area, it may become necessary to provide expansion joints in the underlying screed. It is essential for the screed joints to be created in correspondence of the joints of the ceramic slabs.

To easily help the polymeric sand into the joint, one option is to form slurry by adding water, which allows the jointing material to easily flow into the joint.

The polymeric sand needs to be compressed into the void to ensure a solid joint, if there are any exposed or hungry joints, extra polymeric sand can be swept over them to ensure a compact and full joint.

Ensure that the polymeric sand is fully compacted into the joint after following the instructions above and on the tub.

CLEANING

After installing the Porcelain Pavers, quickly spray the surface with water, to prevent the polymeric sand from hardening and making it more difficult to come off, and sweep off any excess with a soft bristled brush. The remaining polymeric sand can be stored in a tub for up to 6-12 months provided that the tub is filled to the maximum with water so that air cannot enter and ruin it. (The Porcelain Pavers are very low maintenance and easy to clean.).

INCLEMENT WEATHER

If the weather conditions may jeopardize the performance of the paving, the laying and jointing operations should be discontinued. To prevent saturation all the unfinished areas and stockpiles of materials should be covered in the occurrence of inclement weather.

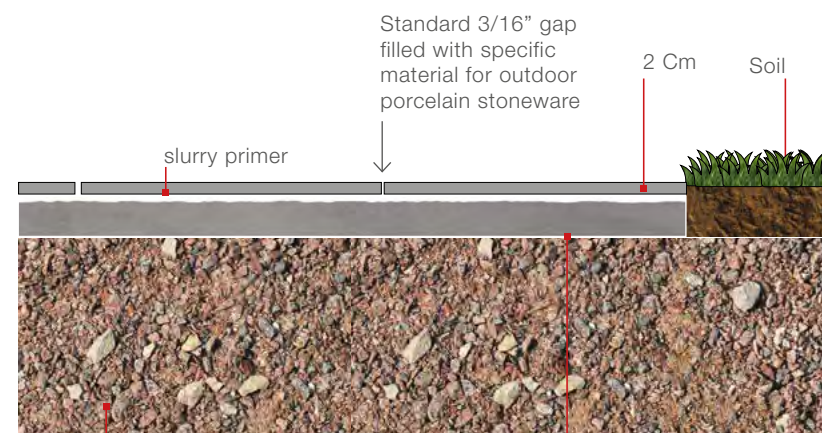

Subgrade Full mortar bed with proper workmanship and complying with the regulations in relation to the specific features of the site and to the type of traffic

Note:

When laying on a screed, it could be advisable to consider using a separating membrane.
http://www.schluter.com/schluter-us/en_US/

http://www.schluter.co.uk/media/552716_Heft_C_Konstruktionsaufbauten_Dachterrasse-GB_0513.pdf

B. FAQ of 2cm/20mm products.

1. Are spacers required for installations in gravel or sand? Can sand be installed in between the tiles, similar to grout?

The answer varies depending on the pavers being rectified or not. As general rule, there must be some space between pavers since otherwise they could easily chip.

' are all rectified therefore the recommended space is 3 mm = 1/8". Initially started with pressed pavers but moved to rectified ones to avoid issues with installation and offer a small grout line option.

It can obviously be more than 3 mm if preferred for better water drainage (in fact the recommended space in between raised installation pavers is 4-5 mm).

Two kinds of spacers are used depending on the installation.
 1 - If the joint is left empty, then we recommend to use a special cross shaped spacer 15 mm tall (5/8") preventing pavers from moving. These spacers were produced specifically for the 2 cm products by a manufacturer since they were usually much shorter than that going between 10 mm tiles.

2 - If the joint is filled up with "polymeric sand/drain mortar" as for interlocking pavers/bricks, then shorter, traditional spacers can be used since the movement of the pavers is prevented by the sand/mortar filler. Still the size of the recommended spacers is 3 mm

2. Can it be installed "buted" against each other?

It is not recommended. It is not doable if the pavers are pressed and not rectified because of the different dimension/calibration of the pieces.

Even if the product is rectified, although it theoretically could be done, it is not recommended because the tiles could chip by friction of one against the other.

3. Does the product get hot in the sun? Are there any tests available or specifications available?

Porcelain gets hot in the sun.

Because of this, we recommend you confirm the materials chosen are suitable for your use, as we will not assume responsibility for any issues regarding temperature of the pavers.

SRI is the measurement of it. Solar index refraction is available for every product. Depending on the color, most of them are ≥ 29 therefore do not significantly increase any urban heat island effect (7.1) and do not contribute to change the energy balance of the environment where they

are installed.

As a result, some porcelain pavers (lighter colors) contribute to the achievement of one sustainable sites credit as per the US Green Building Council standards. Please refer to the attached chart for SRI values.

4. Does this product expand or contract over time due to the chance of temperature?

Porcelain pavers coefficient of linear thermal expansion is very limited @ $6.3 \times 10^{-6} \text{ } ^\circ\text{C}^{-1}$ exceeding the required standard of $< 9 \times 10^{-6} \text{ } ^\circ\text{C}^{-1}$ applied to porcelain tiles as per ISO 10545-8

5. Are there any maintenance requirements? Sealing, etc.

No maintenance other than periodic cleaning is required. No sealing is necessary on porcelain. Cleaning sheets recommendations are supplied by just as for any other porcelain suggesting products and techniques to use.

Running water by a hose is usually the best way to keep the pavers cleaned. Water sitting on the tiles may leave residue of lime/calcium that can be eliminated with a rubber brush. When hosing down pavers installed with drain mortar in between, it is important not to concentrate the stream on the joint since that could wash the sand grout away.

Porcelain pavers are "class 5" as per EN 10545-14 stain resistance test. That means that any stain can be removed with brush and hot water.

6. Are porcelain pavers chemical resistant?

Porcelain pavers are chemical resistant as below, following the standards of ISO 10545 13.2000.

Ua = resistance to domestic and thermal + swimming pool salts

U1 = low concentration acids (i.e. 3% Hydrochloric acid + others)

U2 = high concentration acids (i.e. 18% Hydrochloric acid + others)

7. Does this product stain fade in the sun over time?

Porcelain does not fade in the sun as resulting from DIN 51094 test results.

8. What technical specifications are available for POPAs?

The specs provided are a mix of different regulations and standards.

Based on the european legislation/doctrine, when a new product has not yet been regulated by a specific law, the standards to be followed are the ones of the closest alternative product for which a regulation is in place

In this case we are referring to concrete pavers and raised floors where porcelain standards are not applicable.

- En 1339 is the european standard regulation applied to concrete pavers of less than 1 meter length and a ratio length/thickness ≤ 4
- Iso 10545 are the european standards applied to porcelain tiles
- En 12825 is the european regulation setting the standards applied to raised indoor floors for commercial and industrial applications
- Astm are the standard applied to porcelain tiles in the united states
- Din are the standards applied to porcelain tiles in germany

Copy of the following performed tests are available

Specifically:

- Bending strenght/breaking load (20122372/5) + (20111615/5 italian)
- Frost resistance + desalting ice (20122372/2) + (20111615/5 italian)
- Thermal shock resistance (20122372/1) + 20111615/5 italian
- Slip resistance = usrv (20111615/3 italian)
- Resistance to abrasion (20111615/4 italian)
- Shock test on hard bodies with metal basket (20124267/1)

9. Are porcelain pavers fire resistant?

Yes, they are, as any porcelain tiles, the rating class is a1 as per en13501-1 standard.

10. What is the thermal shock resistance of porcelain pavers? What is the temperature above/below which it is not recommended to install porcelain pavers?

Porcelain pavers pass the thermal shock resistance test iso 10545-8 and can be safely installed in temperature between -40 c (-40 f) and +80 cent (175 f).

Pedestals have a good thermal shock resistance (i.E. Ivica measures 18.7 Kn frost/ defrost) and overall are safely suitable for installation at the above temperatures (please refer to manufacturers specs)

TECHNICAL CHARACTERISTICS

STANDARDS	CHARACTERISTICS OR PROPERTIES	COMPLIANCE WITH STANDARDS UNI EN 14411 G ASTM	DECLARED VALUE
ISO - 10545-3 ASTM - C 373-88	Water absorption	E < = 0.5 %	< 0.1 %
ISO - 10545-9 ASTM - C 484	Thermal shock resistance	Requested	Complies with standard
ISO - 10545-12 ASTM - C 1026	Frost resistance	Requested	Complies with standard
ISO - 10545-6 ASTM C - 1243-93	Abrasive wear	<175 mm ²	139 mm ²
ISO - 10545-2	Straightness / ASTM - C 485	+/- 0.75 % (+/- 1.8 mm)	Complies with standard
	Straightness / ISO - 10545-2	+/- 0.5 % (+/- 1.5 mm)	Complies with standard
	Thickness / ASTM - C 499	+/- 1.02 mm	Complies with standard
	Thickness / ISO - 10545-2	+/- 0.5 % (+/- 0.5 mm)	Complies with standard
	Length and width / ASTM - C 499	+/- 0.5 % (+/- 2.0 mm)	Complies with standard
	Length and width / ISO - 10545-2	+/- 0.6 % (+/- 2.0 mm)	Complies with standard
ISO - 10545-4 Bending strength in N (thickness > = 7.5 mm)	ASTM - C 648	> = 250 LBF Average	> = 225 LBF Individual
	ISO - 10545-4	> = 1300 Newton	> 13000
ASTM - C 650	Chemical resistance	As reported	Resistant
ISO 10545-14	Resistance to stain	-	5
ISO 10545-13	Chemical resistance	UB min.	UA ULA UHA
ISO 10545-8	Coefficient of linear thermal-expansion	-	$\alpha=6.3 \times 10^{-6} \text{ }^{\circ}\text{C}^{-1}$
ISO 10545-5	Impact resistance	-	0.88
EN 12825	Static load	-	Centre 9.6 Kn Centre point of sides 6.5 Kn Diagonal 8.19 Kn (CLASSE 3)
	Dymanic laod capacity - hand object impact test	-	Test not passed
	Dymanic laod capacity - soft object impact test	-	Test passed
EN 1339	Bendind strength - breaking force in N the data measured lead to the presumed attribution not less than Class U11 for load	Kn 14.38	classe 14
ENV 12633	Slip resistance	> / = CL1	CL 2
DIN 51130	Slip resistance	-	R11
DIN 51097	Slip resistance	-	A + B + C min.
DM 236/89 B.C.R.A.	Slip resistance	-	> 0.40
Static coefficient of friction ASTM 1028-07 BOT 3000 Dynamic coefficient of friction (sectio n 9.6 ANSIA 137.1 2012)	Slip resistance	-	> 0.60 WET > 0.60 DRY > = 0.42
EN 13501-1	Fire resistance	-	A1 - A1 FL



ADDRESS

115 Carnarvon Street
Toronto, Ontario

M6M 3C9

416 413 9008

ADDRESS

Michigan Design Center
1700 Stutz Drive

Ste 92 & 94
Troy, Michigan 48084

248 643 6520